

No.	REVISIONS	DATE
1	ADD NOTE #6. STANDARD 1/8" REVEAL, REVISE CHART	9/25/89
2	EXTENSIVE DRAWING CHANGES - SEE TRN # T-80	8/6/92
3	REVISED FROM 5/16" DRILL TO 1/4" DRILL 1" DEEP	8/2/04

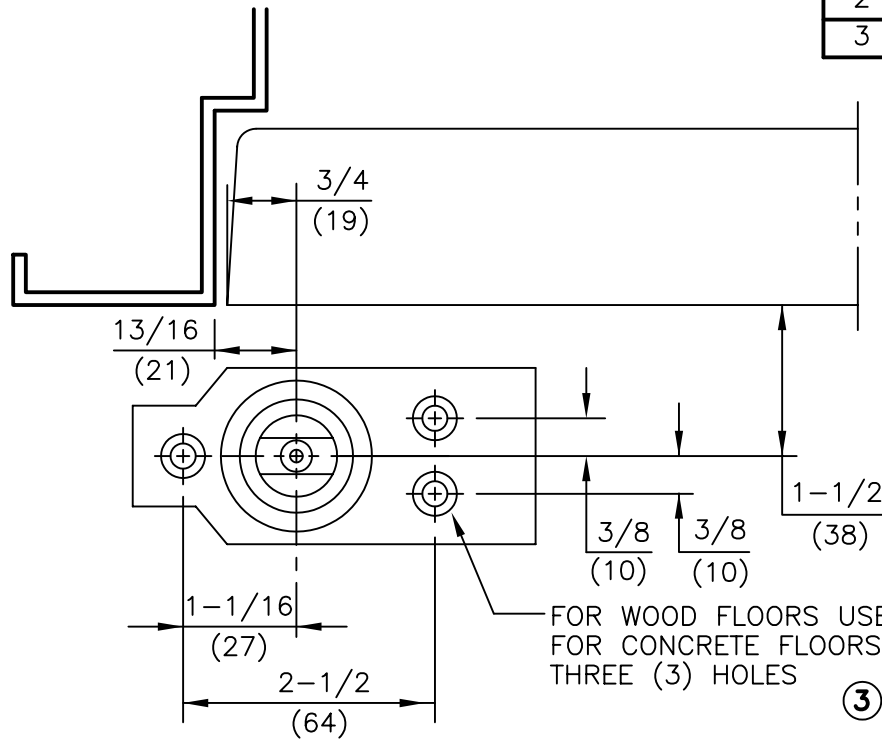

NOTES:

1. DO NOT SCALE DRAWING.
2. DIMENSIONS ARE IN INCHES\MM.
3. RIGHT HAND DOOR SHOWN.
4. DIMENSION "A" IS DISTANCE FROM BOTTOM OF PIVOT TO BOTTOM OF ARM. WHEN BOTTOM ARM IS INSTALLED TO THE STANDARD TEMPLATE, THIS IS ALSO EQUAL TO THE BOTTOM DOOR CLEARANCE.

SPINDLE SIZE	DIM. "A"
STANDARD	11/16 (17)
5MM EXT.	7/8 (22)
10MM EXT.	1-1/16 (27)
15MM EXT.	1-1/4 (32)
20MM EXT.	1-7/16 (37)
25MM EXT.	1-5/8 (42)
30MM EXT.	1-7/8 (47)
35MM EXT.	2-1/16 (52)
40MM EXT.	2-1/4 (57)
45MM EXT.	2-7/16 (62)
50MM EXT.	2-5/8 (67)

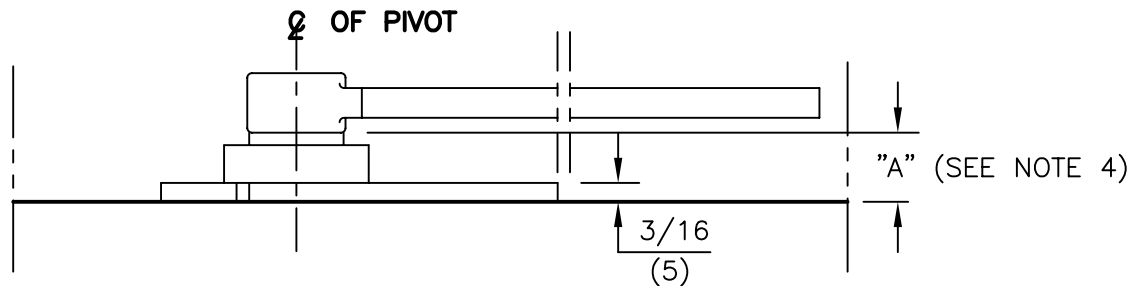

ITEM No.7471K
1-1/2" OFFSET FLOOR BEARING INSTALLATION



DORMA Architectural Hardware
REAMSTOWN, PENNSYLVANIA 17567
TEMPLATE No. LM-31 (3)

NOTES

1. DO NOT SCALE DRAWING.
2. DIMENSIONS ARE IN INCHES/(MM).
3. RIGHT HAND DOOR SHOWN.
4. BEVEL HEEL EDGE OF DOOR 1/8" IN 2".
5. ALL NECESSARY REINFORCING FOR PIVOT BY OTHERS.
6. STANDARD MORTISE DEPTH.

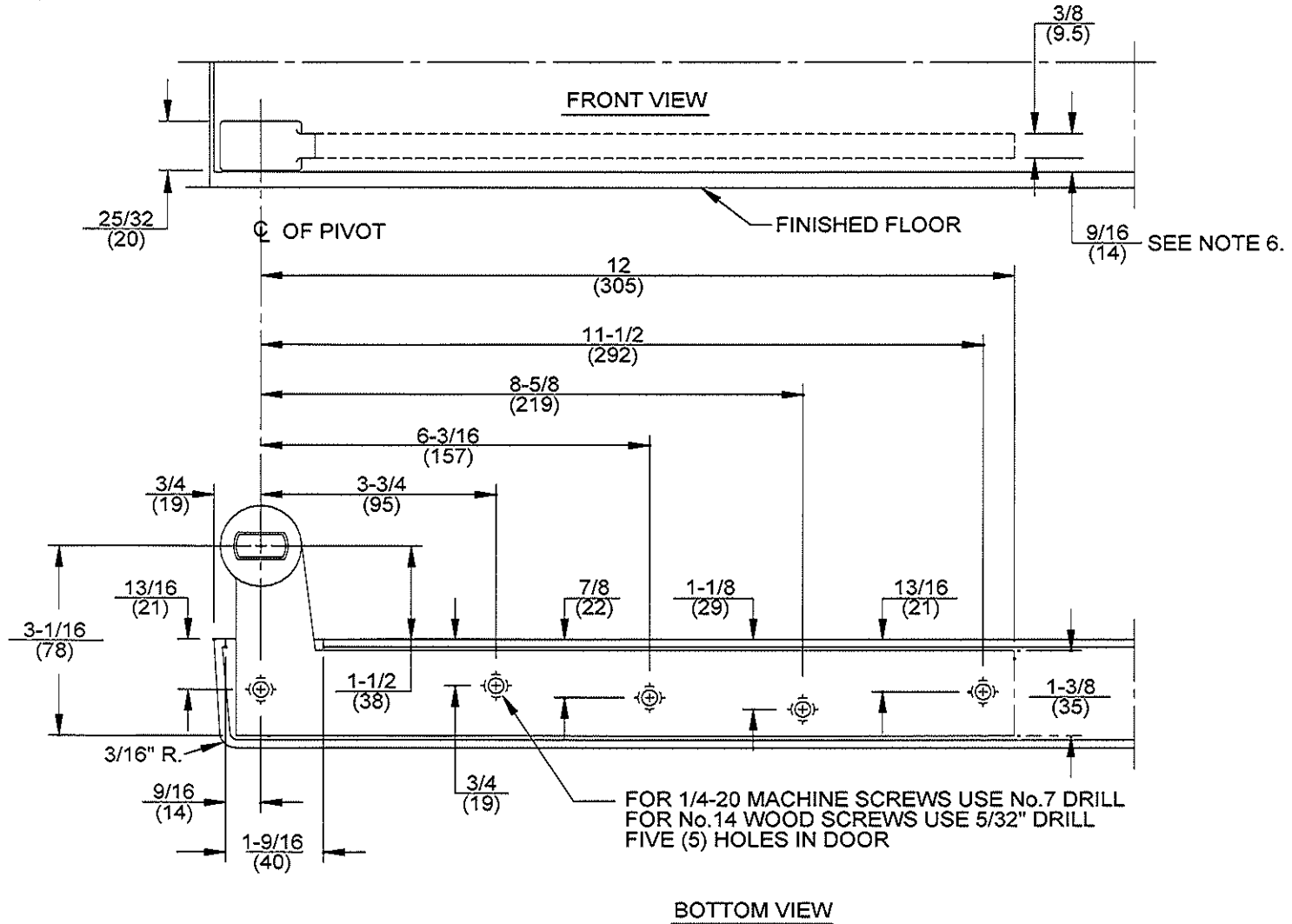

ITEM No. 15323
 1-1/2" OFFSET STANDARD BOTTOM ARM (HANDED)



DORMA Architectural Hardware
 Reamstown, PA 17567

TEMPLATE No. 15200

No.	REVISIONS	DATE

FOR 1/4-20 MACHINE SCREWS USE No.7 DRILL
 FOR No.14 WOOD SCREWS USE 5/32" DRILL
 FOUR (4) HOLES PER LEAF

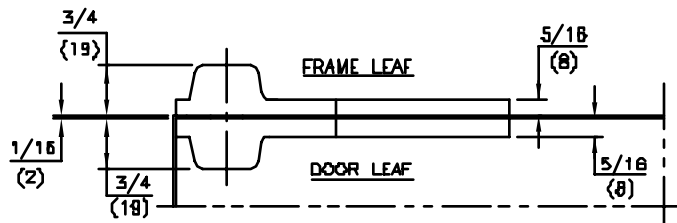
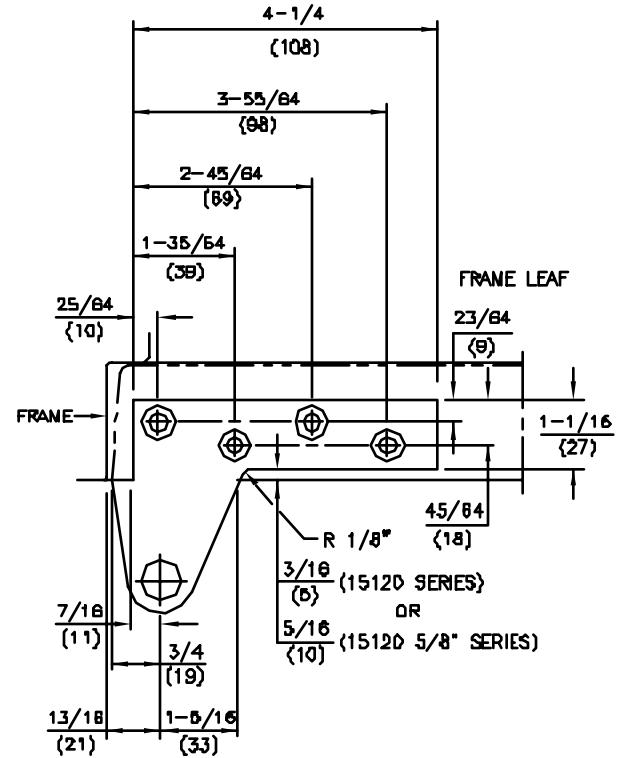
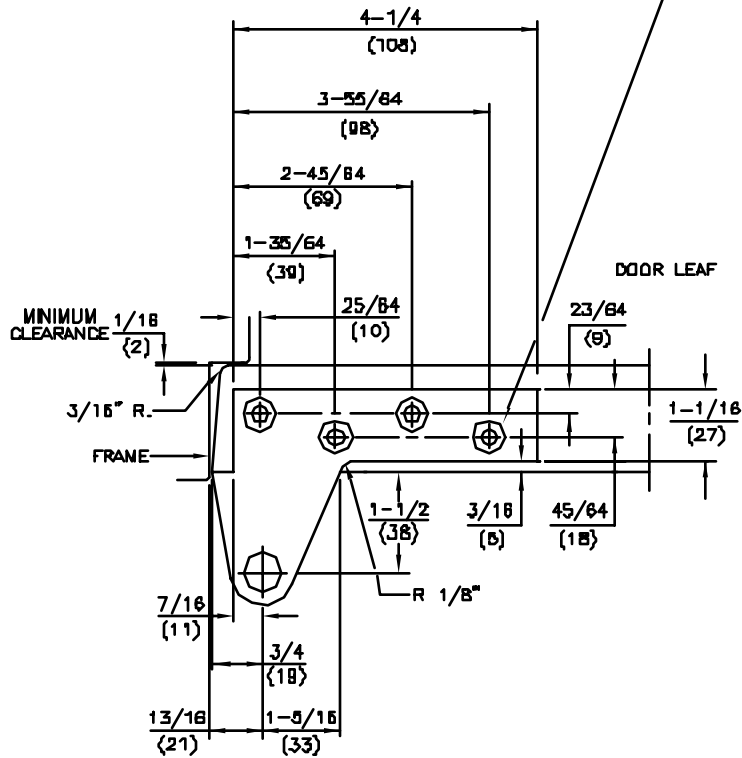

NOTES

1. DO NOT SCALE DRAWING.
2. DIMENSIONS ARE IN INCHES/(MM).
3. RIGHT HAND DOOR SHOWN.
4. BEVEL HEEL EDGE OF DOOR 1/8" IN 2".
5. ALL NECESSARY REINFORCING FOR PIVOT BY OTHERS.

ITEM No. [15120, 15122, 15133 (FLUSH DOOR) NON-HANDED],
 [15120 5/8, 15122 5/8, 15133 5/8 (1/8" REVEAL) HANDED]
 1-1/2" OFFSET FULL MORTISE TOP PIVOT



DORMA Architectural Hardware
 REAVISTOWN, PENNSYLVANIA 17567
 TEMPLATE No. LM-38