

Door Size	A	B	Max. Lead Thk.
1-3/4	1-1/4	1/4	9/32-7.14mm
2"	1-3/8	5/16	3/8-9.52mm
2-1/4	1-1/2	3/8	15/32-11.90mm
2-1/2	1-5/8	7/16	9/16-14.28mm
3"	2"	1/2	3/4-19.05mm

Table based on lead placed in center of door.

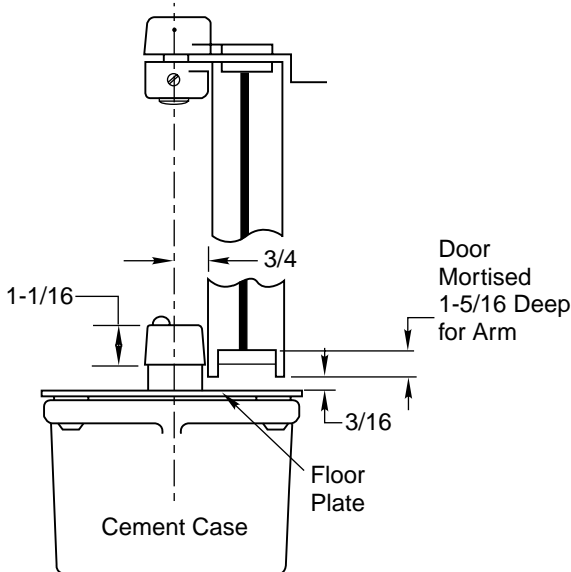

WITH FLOOR PLATE
Set Cement Case 1/8" Below Surface of Finished Floor

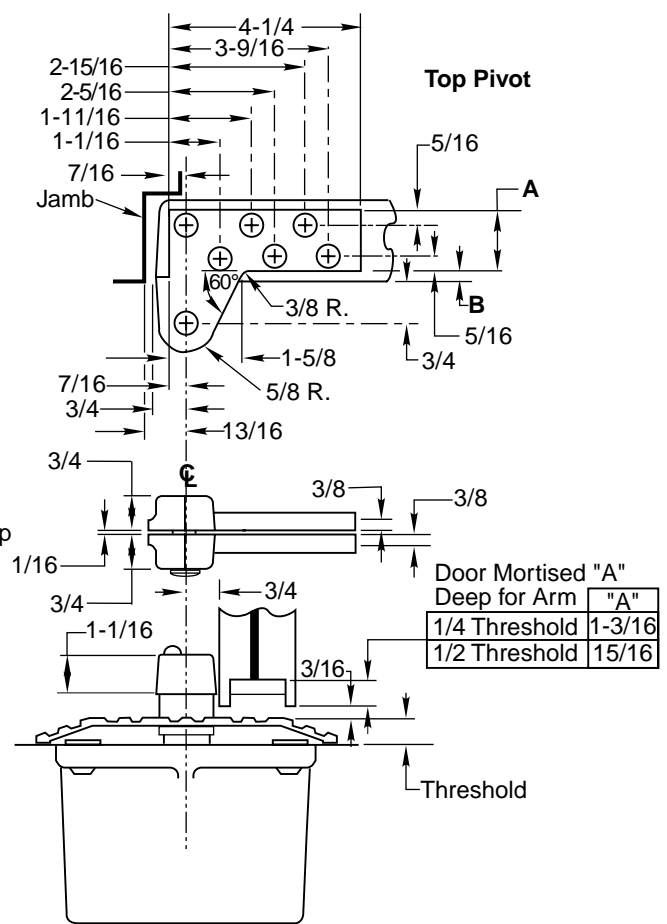

WITH THRESHOLD
Set Cement Case Flush with Finished Floor

Door Mortised "A" Deep for Arm	"A"
1/4 Threshold	1-3/16
1/2 Threshold	15/16

- Note:
1. Do not scale drawing.
 2. Right Hand Shown
 3. Dimensions given in inches. Conversion from inches to metric: inch x 25.4
 4. Arm and pivot leaf drilled to receive 2" #14 FHWS or 1" x 1/4-20 FHMS.
 5. For Wood Doors: Pre-drill arm and top pivot holes to prevent splitting.
 6. If vertical adjustment is required two 1/16" shims are provided. Place shims between arm and spindle shoulder collar.
 7. Max degree of opening, trim permitting, is 105°. Suitable reinforcing by others. Leadlining by others.

L27 Heavy Duty Floor Closer
3/4" Offset

RIXSONTM
Rixson Specialty Door Controls
www.rixson.com
 TEMPLATE NUMBER **OS10080** DATE **5-06**