

NO.	QTY.	PART NAME	MATERIAL
1	1	RIVET PIN	STEEL
2	2	LONG PIN	STEEL
3	12	LINK	STEEL
4	2	CHANNEL PIN	STEEL
5	2	BODY	ZINC
6	2	LONG ROLLER	NYLON 6/6
7	2	SPACER	NYLON 6/6
8	2	SHORT ROLLER	NYLON 6/6
9	8	LINK	NYLON 6/6

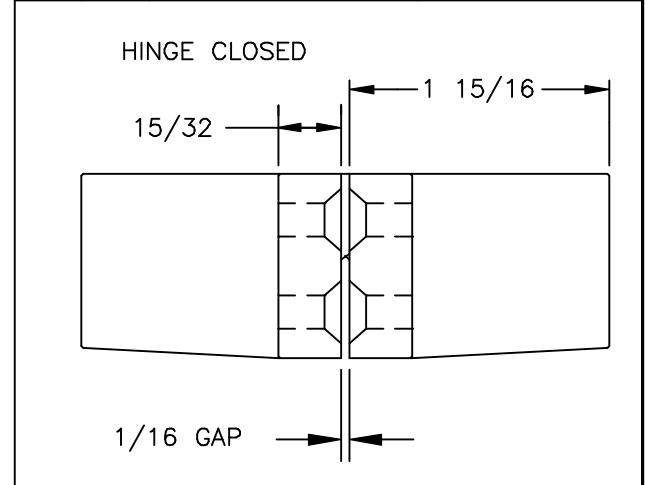

#12 X 1-1/2" WOOD SCREWS SUPPLIED
 #12-24 X 1" MACH. SCREWS CAN BE SPECIAL ORDERED
 2 INCH MIN. WOOD DOOR THICKNESS
 DO NOT SCALE DRAWING
 THE 2" DEPTH PROVIDES 1/16 CLEARANCE IN
 THE BOTTOM OF THE MORTISE
 DOOR CLEARANCE REDUCES TO 1/64" WHILE CLOSING
 SEE DWG# 4477-C IF ADDING MATERIAL TO DOOR FACE

UIP © Copyright 1998 Universal Industrial Products Co. Inc. One Coreway Drive Pioneer, Ohio 43554-0628	SCALE: NOT TO SCALE
	DRAWN BY: R. SEIGNEUR
HINGE TEMPLATE	DATE: 4/8/98
#220 SOSS INVISIBLE HINGE	DRAWING # 3953-C