

AN 170 3D

DIT\_SP\_035 rev.0 01/09/2019

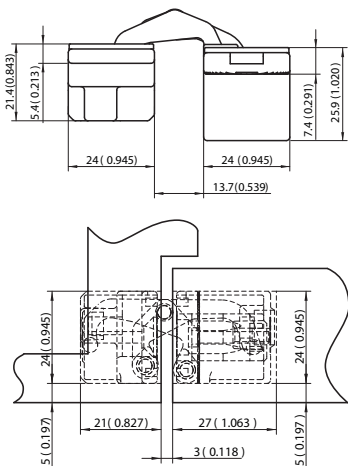
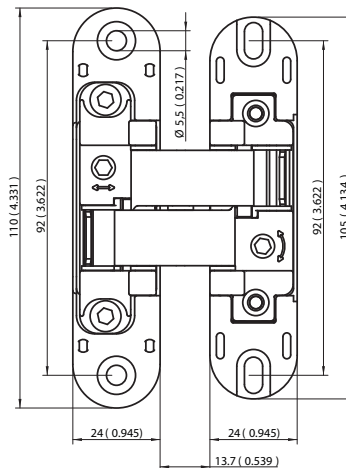

## MILLING

### Frame

### Door

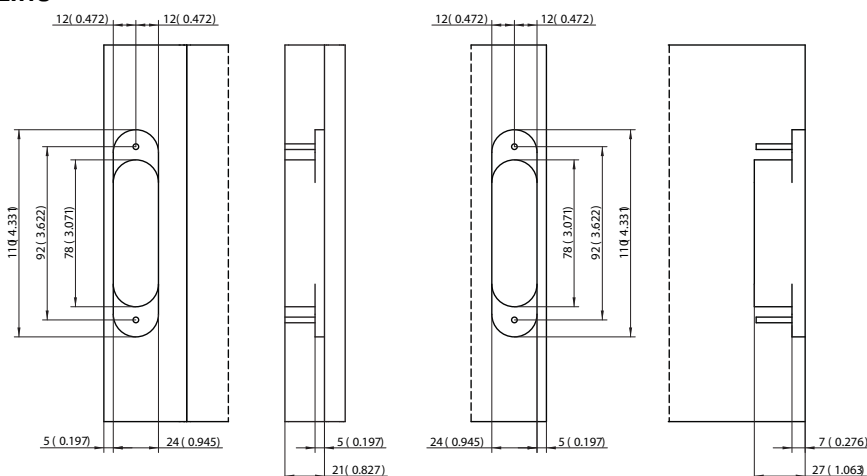

## Screw Information

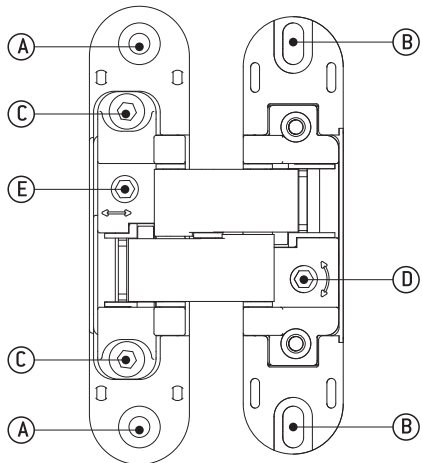

**A** Screw hole for the hinge to the frame.

**D** Self-locking screw for side adjustment.

**B** Oval holes for vertical adjustment and anchoring to the door.

**E** Depth adjustment screw.

**C** Clamping screw for depth adjustment screw.

## Height Adjustment

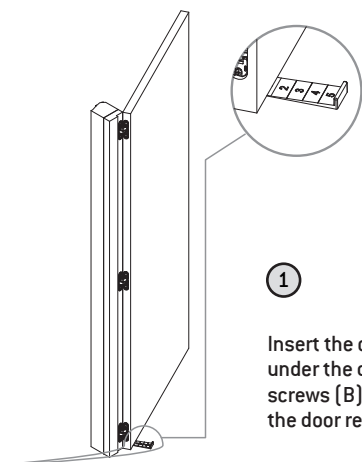

1

Insert the optional adjustment wedge under the door and unscrew the anchoring screws (B) of the hinge on the door; the door rests on the wedge.

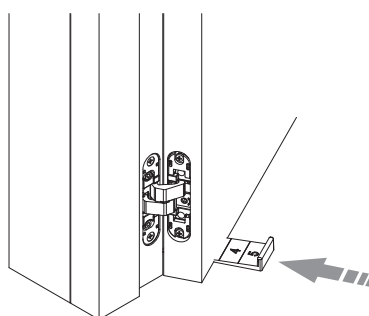

2

Slide the wedge under the door until the desired height is achieved, re-tighten the screws.

## Depth Adjustment

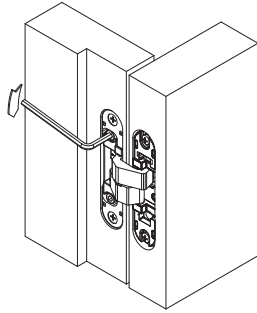

1

Loosen the two clamping screws (C).

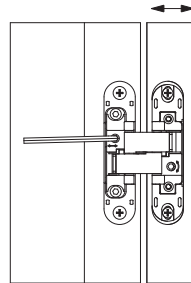

2

Turn the depth adjustment screw (E) to the desired compression.

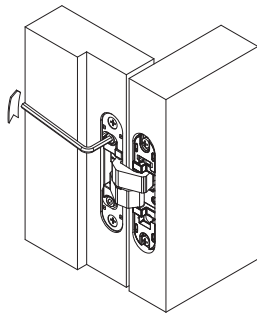
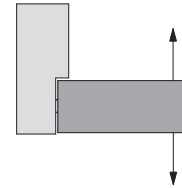

3

Tighten the two clamping screws (C).

## Side Adjustment

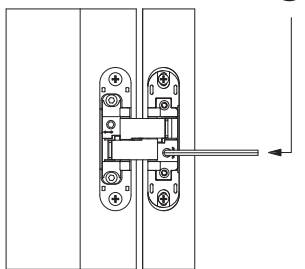

2

Turn the side adjustment screw (D) clockwise for decreasing the air gap by a max. of 1.5 mm (.059").

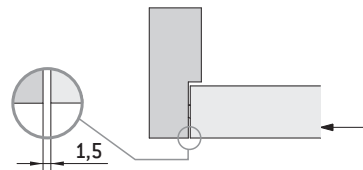

2

Turn the side adjustment screw (D) counterclockwise for increasing the air gap by a max. of 1.5 mm (.059").

