

Installation Instructions

50554 (04-09)

Template

Model	Function
501- (Size)	Single Acting

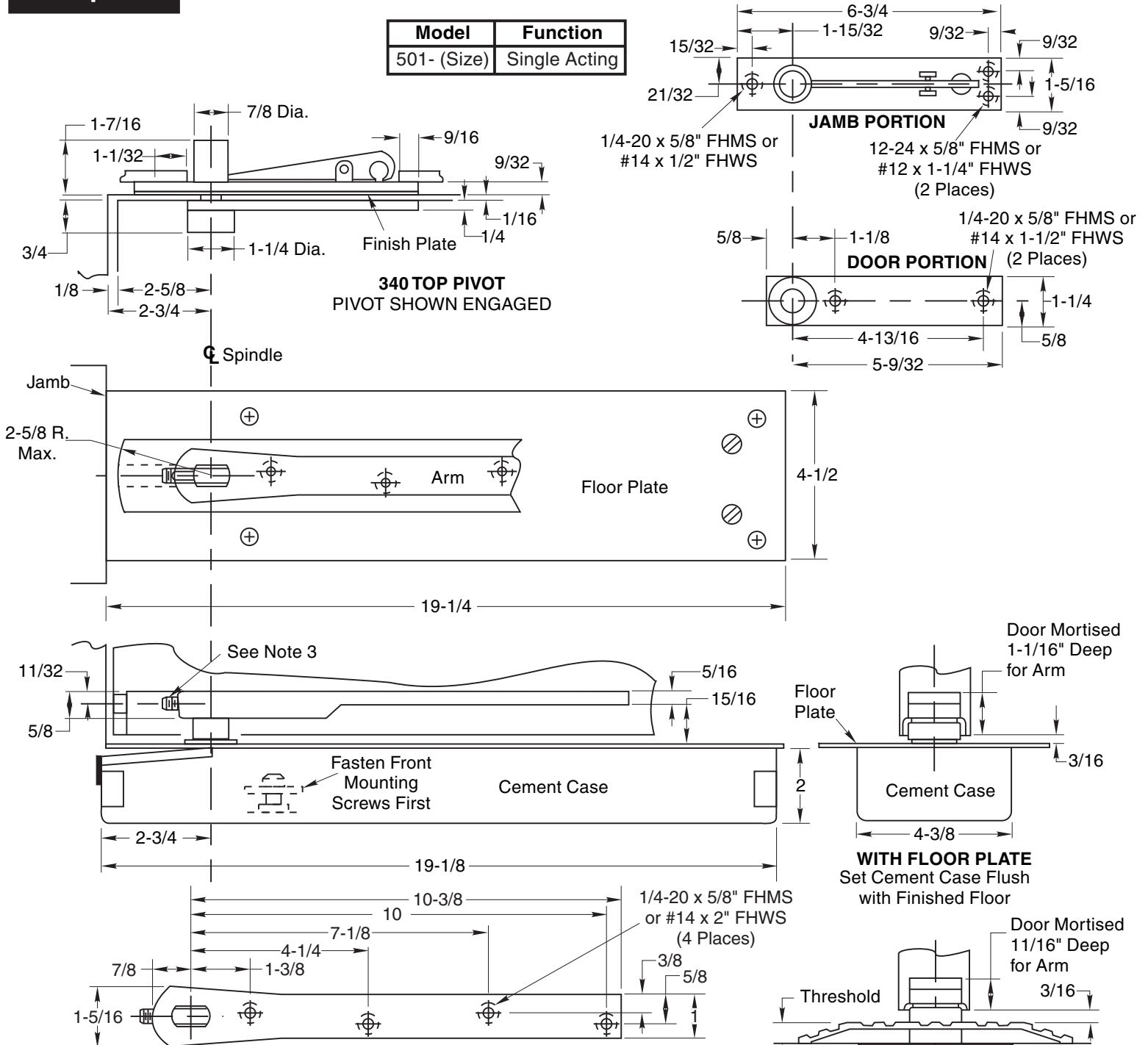

Notes:

1. Do not scale drawing.
2. Suitable reinforcing by others.
3. After mounting door, lock arm on spindle with 5/16-18 x 3/4" hex head socket set screw. Use 5/32" Allen wrench provided to securely lock arm. A 1/2" dia. hole in heel edge of door must be provided for access to set screw.
4. Do not remove grind plate until closer is installed.
5. External stop required by others.
6. Rixson design threshold available on request.
7. 1/2" extended spindle must be used with threshold application.
8. All dimensions given in inches. Conversion from inches to metric: inch x 25.4.

How To Determine Hand of Door

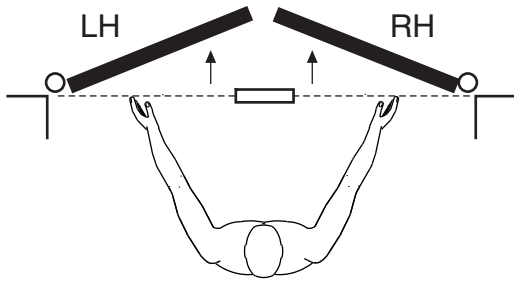

Face a door swinging open away from you. If it opens to the right, it is right hand. If it opens to the left, it is left hand.

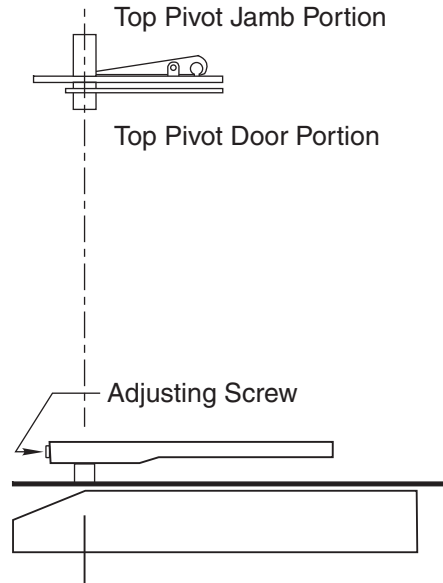

IMPORTANT:

Use plumb line to make sure that center line of top pivot pin lines up with center line of closer spindle.

Installation Instructions

1. Locating Closer

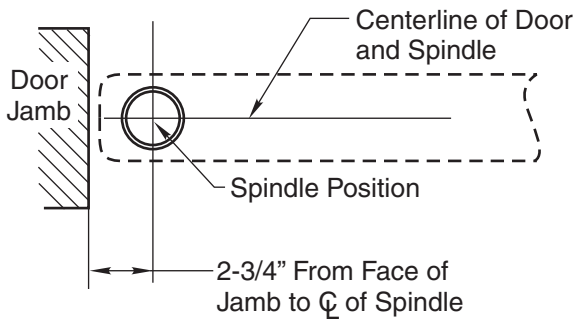

- A. Measure 2-3/4" out from door jamb on centerline of door. This is the location of the spindle center.

2. Install Cement Case in Floor

LEVEL IN BOTH DIRECTIONS

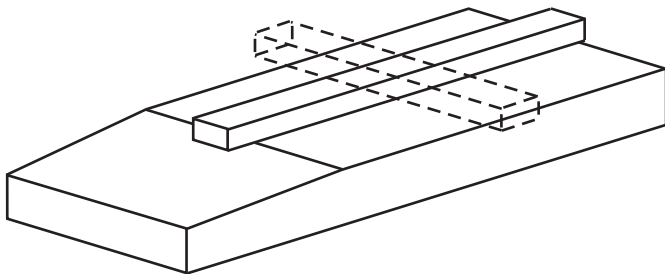

- A. Cement case is set flush with finished floor.
- B. Set cement case with closer in floor and block in position.
- C. Case should be parallel with center line of door.
- D. CEMENT CASE SHOULD BE LEVEL. Place levels per Illustration.
- E. Grout in cement case with closer. Cement should not get between closer and case.

3. Install Top Pivot and Closer Arm

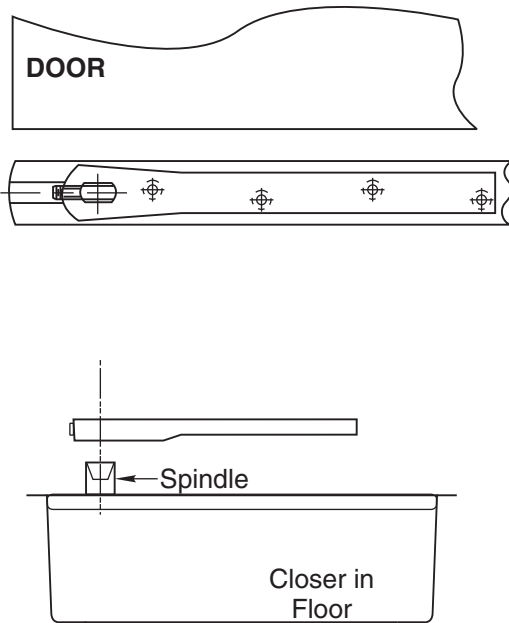

- A. Install top pivot in door per template.
- B. Install top pivot in jamb per template.
- C. Centerline of pivot pin should line up with centerline of spindle. Use plumb line to assure accuracy. If center lines don't line up, loosen hold down screws (4) and reposition closer. Tighten hold down screws closest to spindle first. Then tighten screws at cylinder end. Note: Closer must be lifted approx. 1/8" before repositioning.
- D. Mortise door for arm. Refer to template.
- E. Drill 1/2" hole at heel edge of door for locking screw.
- F. After mounting door, lock arm on spindle with 5/16"-18 x 3/4" long hex. socket set screw. Use 5/32" allen wrench provided to securely lock arm. A 1/2" dia. hole in heel edge of door must be provided for access to set screw.

4. Hang Door

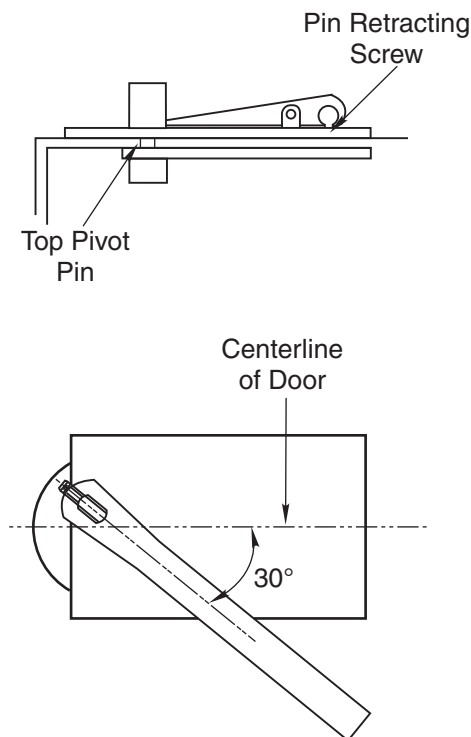

CAUTION: Closer is shipped with "valve" screws down. DO NOT FORCE VALVE DOWN.

- A. Close both valve screws. NEVER FORCE VALVE SCREW DOWN AS THIS WILL DAMAGE TIP SEATING.
- B. With arm on spindle, turn spindle until arm is in 30° open position (see illustration).
- C. Set door on spindle. DO NOT ATTEMPT TO CLOSE DOOR.
- D. Align two portions of top pivot and turn pin retracting screw clockwise to engage top pivot pin.
- E. Open door to 60° or more and turn valve screws counterclockwise. Door will then close.
- F. Turn Lock Screw at bottom heel edge of door to securely lock arm to spindle.

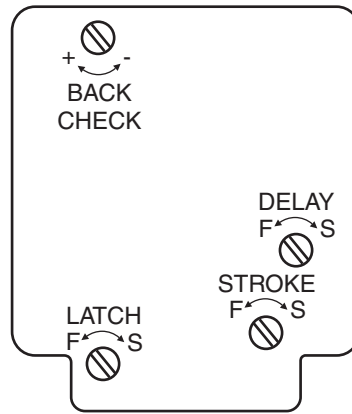

Closing speeds can be adjusted to suit local conditions and requirements. Label on closer face designates the purpose of each adjustment screw. Adjustments are for speed control.

- A. The stroke valve allows adjustment from open to 15°.
- B. The latch valve allows adjustment from 15° to closed position.
- C. **IMPORTANT:** Back check valve option must be adjusted to vary resistance from light to firm at 70° of door opening.
- D. The delay valve option allows closing speed adjustment from open position to 65°.

Repairs, parts replacement or internal adjustments must be done by a Rixson authorized repair agency. Consult www.rixson.com for an authorized repair agency in your area.