

### Template

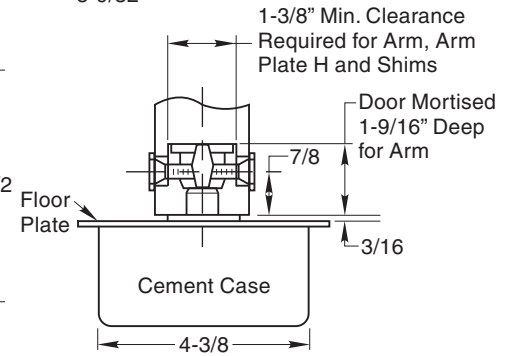

**WITH FLOOR PLATE**  
Set Cement Case Flush with Finished Floor

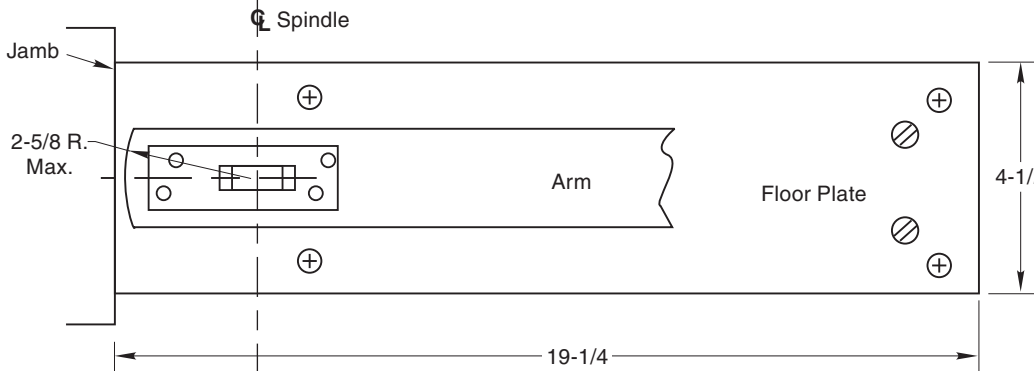
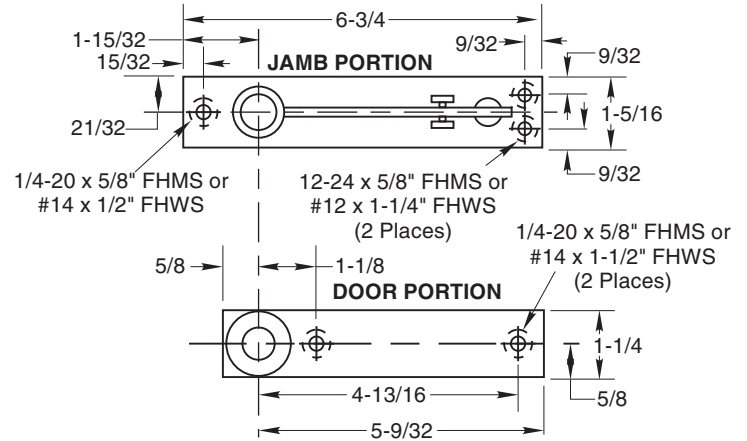
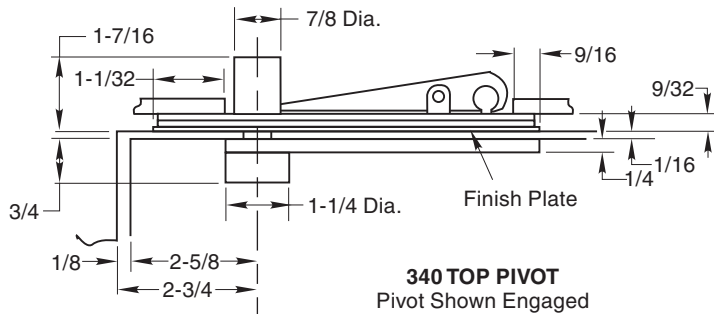
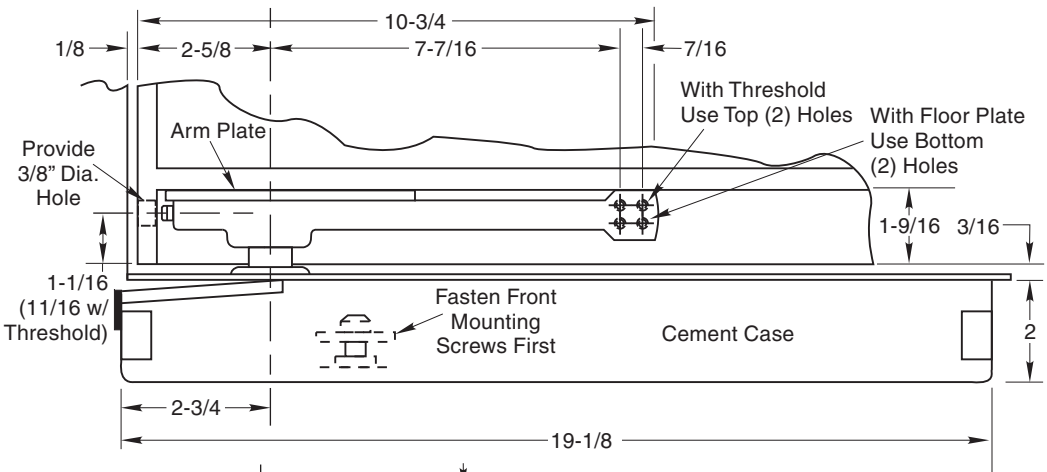

Door Mortised Deep for Arm	A	B
1/4 Threshold	1-13/16	1-1/8
1/2 Threshold	1-9/16	7/8

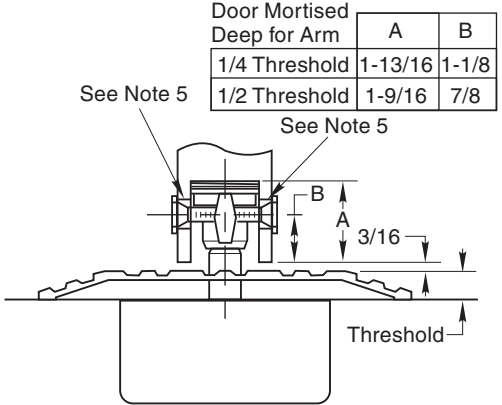

**WITH THRESHOLD**  
Set Cement Case Flush with Finished Floor

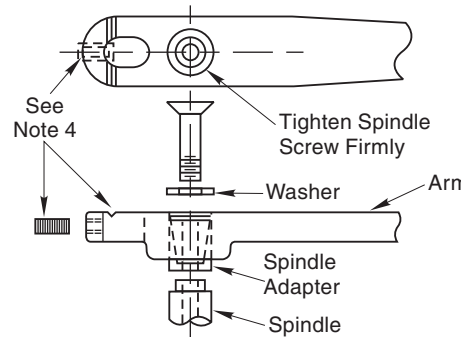
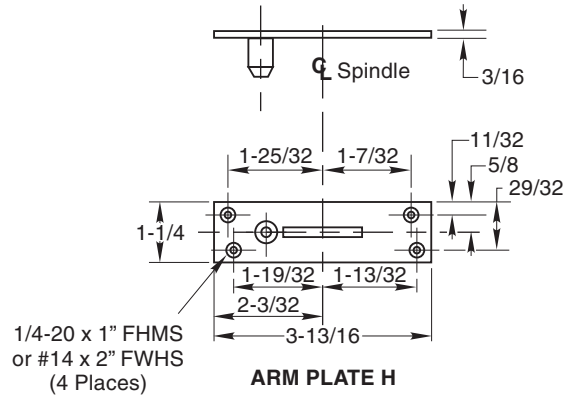

**Notes:**

- Do not scale drawing.
- Suitable reinforcing by others.
- Rixson design threshold available on request.
- Tighten adjusting screw to notched "V" line on arm to acquire standard initial location of door. Screw moves door towards and away from jamb to equalize door clearances.
- Provide 5/8" dia. holes for alignment screws (2 places).
- Do not remove grind plate until closer is installed.
- External stop by others required.
- All dimensions given in inches.

Conversion from inches to metric: inch x 25.4.

## How To Determine Hand of Door

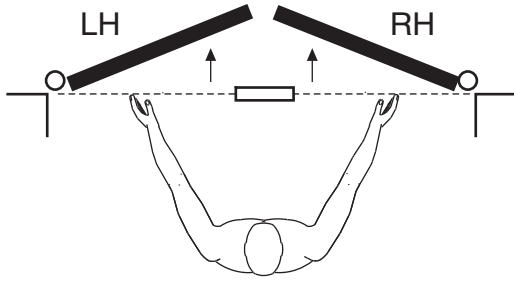

Face a door swinging open away from you. If it opens to the right, it is right hand. If it opens to the left, it is left hand.

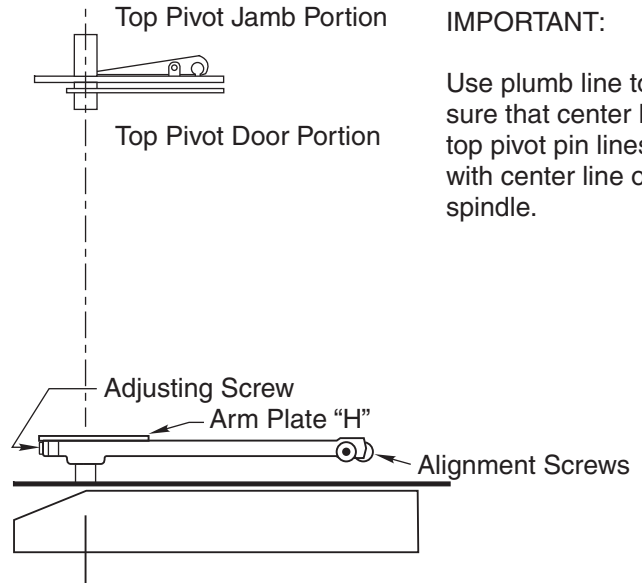

**IMPORTANT:**

Use plumb line to make sure that center line of top pivot pin lines up with center line of closer spindle.

## Installation Instructions

### 1. Locating Closer

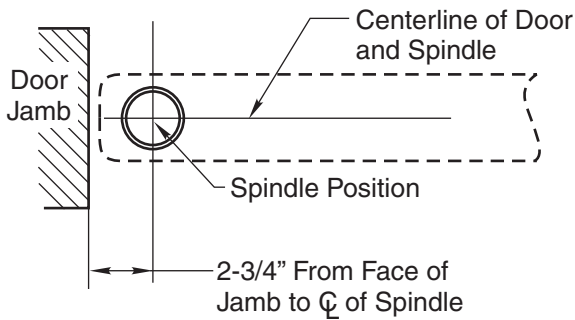

- A. Measure 2-3/4" out from door jamb on centerline of door. This is the location of the spindle center.

### 2. Install Cement Case in Floor

LEVEL IN BOTH DIRECTIONS

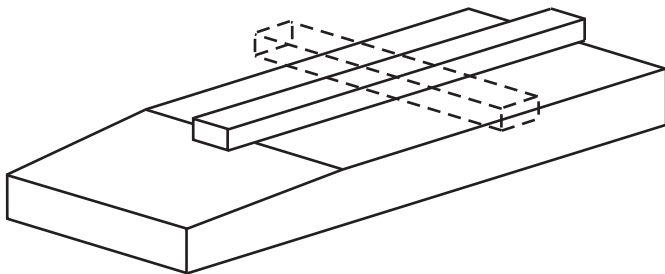

- A. Cement case is set flush with finished floor.
- B. Set cement case with closer in floor and block in position.
- C. Case should be parallel with center line of door.
- D. CEMENT CASE SHOULD BE LEVEL. Place levels per Illustration.
- E. Grout in cement case with closer. Cement should not get between closer and case.

### 3. Install Top Pivot and Closer Arm

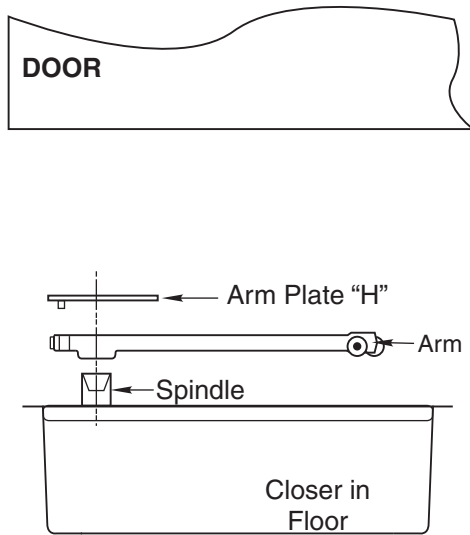

- A. Install top pivot in door per template.
- B. Install top pivot in jamb per template.
- C. Centerline of pivot pin should line up with centerline of spindle. Use plumb line to assure accuracy. If center lines don't line up, loosen hold down screws (4) and reposition closer. Tighten hold down screws closest to spindle first. Then tighten screws at cylinder end. Note: Closer must be lifted approx. 1/8" before repositioning.
- D. Mortise door for arm, arm plate H, and wood door arm plate. Refer to template.
- E. Drill two 5/8" dia. holes for arm alignment screws. Drill 3/8" hole at heel edge of door for adjusting screw.
- F. Install arm, arm plate H, and shims if required. Attach arm alignment screws and washers to hold arm in place.

### 4. Hang Door

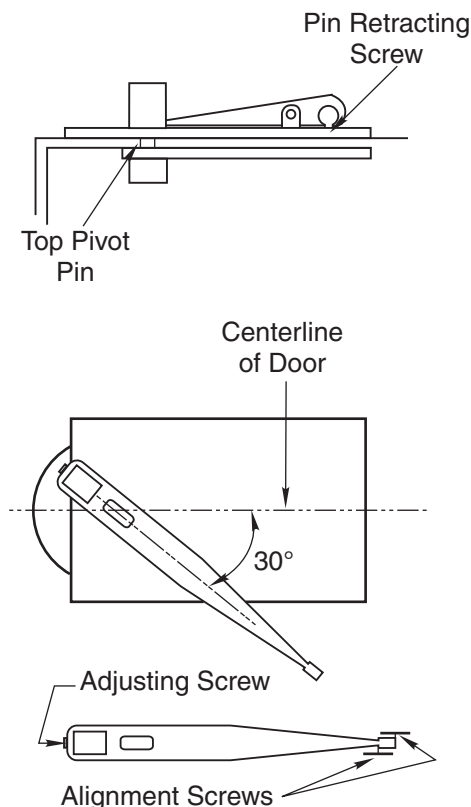

**CAUTION:** Closer is shipped with "valve" screws down. DO NOT FORCE VALVE DOWN.

- A. Close both valve screws. NEVER FORCE VALVE SCREW DOWN AS THIS WILL DAMAGE TIP SEATING.
- B. With arm on spindle, turn spindle until arm is in 30° open position (see illustration).
- C. Set door on spindle. DO NOT ATTEMPT TO CLOSE DOOR.
- D. Align two portions of top pivot and turn pin retracting screw clockwise to engage top pivot pin.
- E. Open door to 60° or more and turn valve screws counterclockwise. Door will then close.
- F. If necessary, turn adjusting screw at bottom of heel edge of door to equalize side jamb clearances.
- G. Adjust arm alignment screws equally from each side to center door in doorway.

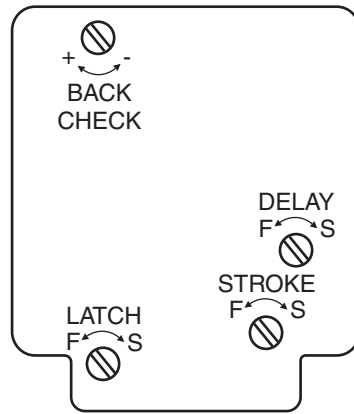

Closing speeds can be adjusted to suit local conditions and requirements. Label on closer face designates the purpose of each adjustment screw. Adjustments are for speed control.

- A. The stroke valve allows adjustment from open to 15°.
- B. The latch valve allows adjustment from 15° to closed position.
- C. **IMPORTANT:** Back check valve option must be adjusted to vary resistance from light to firm at 70° of door opening.
- D. The delay valve option allows closing speed adjustment from open position to 65°.

Repairs, parts replacement or internal adjustments must be done by a Rixson authorized repair agency. Consult [www.rixson.com](http://www.rixson.com) for an authorized repair agency in your area.

## Template

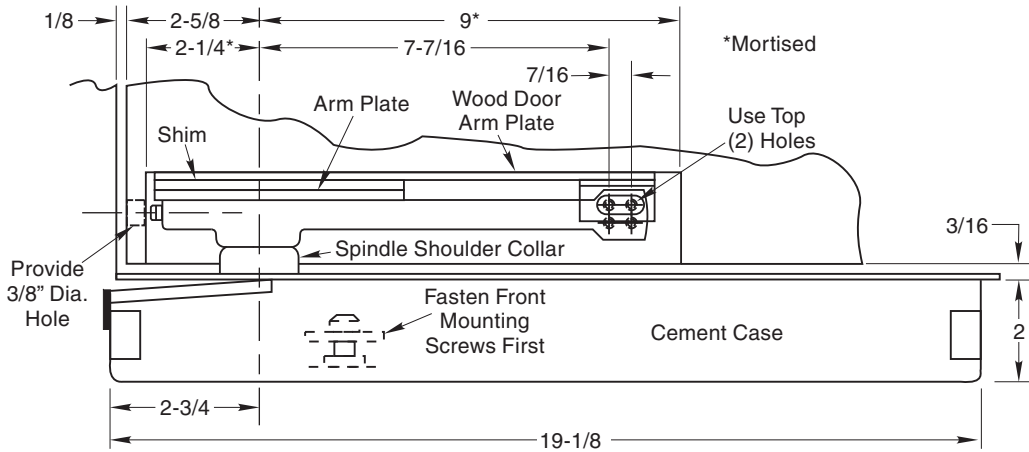
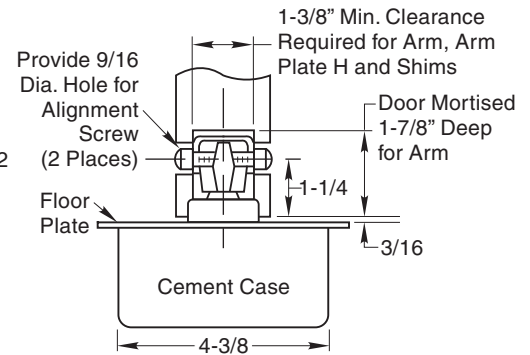
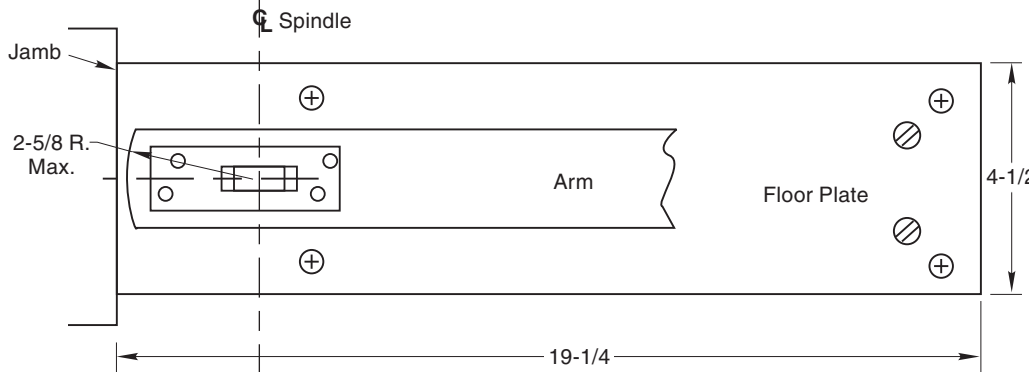
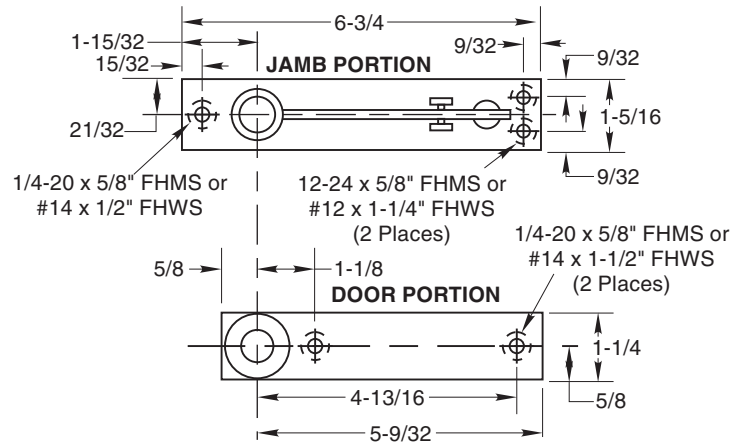
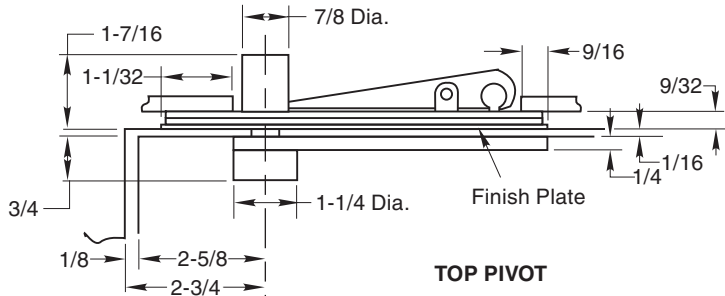

Provide 9/16 Dia. Hole for Alignment Screw (2 Places)

Door Mortised Deep for Arm

	A	B
1/4 Threshold	1-3/4	1-1/8
1/2 Threshold	1-1/2	7/8

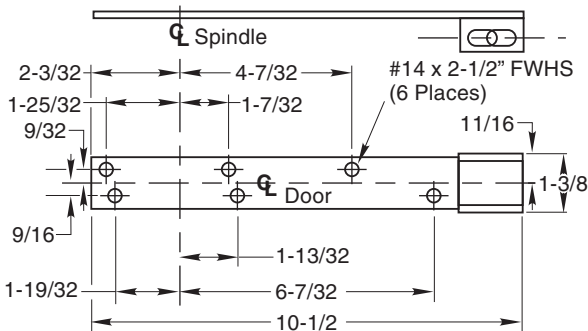
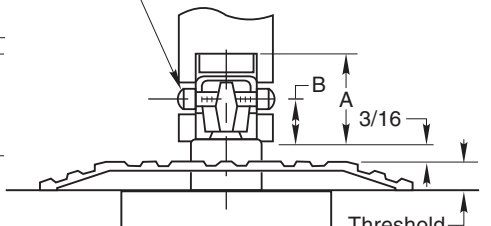

**WOOD DOOR ARM PLATE**

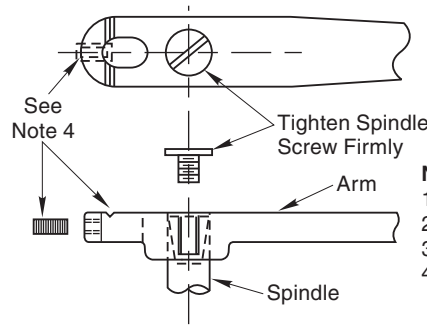

**Notes:**

- Do not scale drawing.
- Suitable reinforcing by others.
- Rixson design threshold available on request.
- Tighten adjusting screw to notched "V" line on arm to acquire standard initial location of door. Screw moves door towards and away from jamb to equalize door clearances.
- Auxiliary stop required.
- All dimensions given in inches.

Conversion from inches to metric: inch x 25.4.

## How To Determine Hand of Door

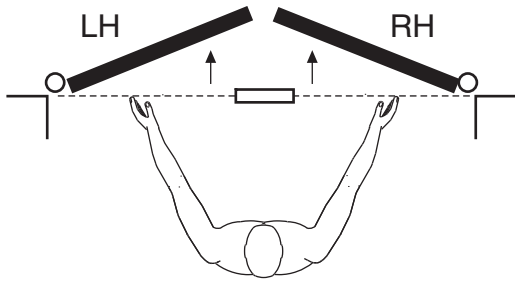

Face a door swinging open away from you. If it opens to the right, it is right hand. If it opens to the left, it is left hand.

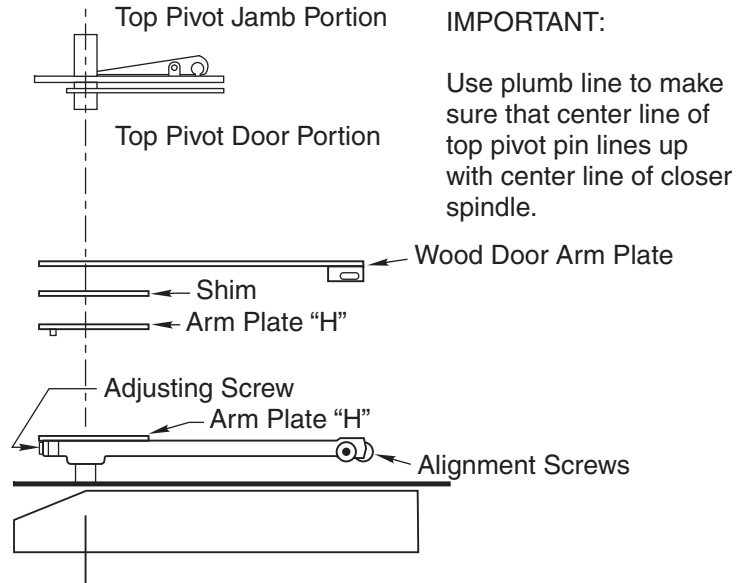

## Installation Instructions

### 1. Locating Closer

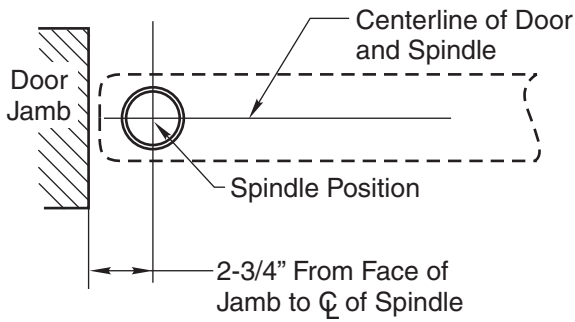

- A. Measure 2-3/4" out from door jamb on centerline of door. This is the location of the spindle center.

### 2. Install Cement Case in Floor

LEVEL IN BOTH DIRECTIONS

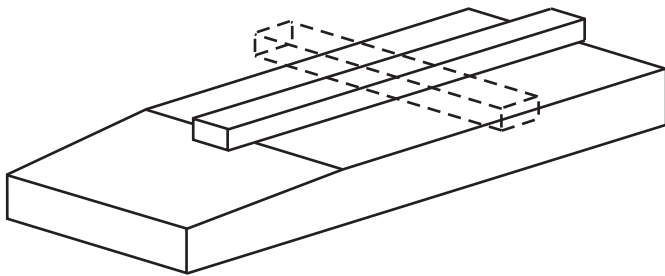

- A. Cement case is set flush with finished floor.
- B. Set cement case in floor and block in position.
- C. Case should be parallel with center line of door.
- D. CEMENT CASE SHOULD BE LEVEL. Place levels per Illustration.
- E. Grout in cement case with closer. Cement should not get between closer and case.

### 3. Install Top Pivot and Closer Arm

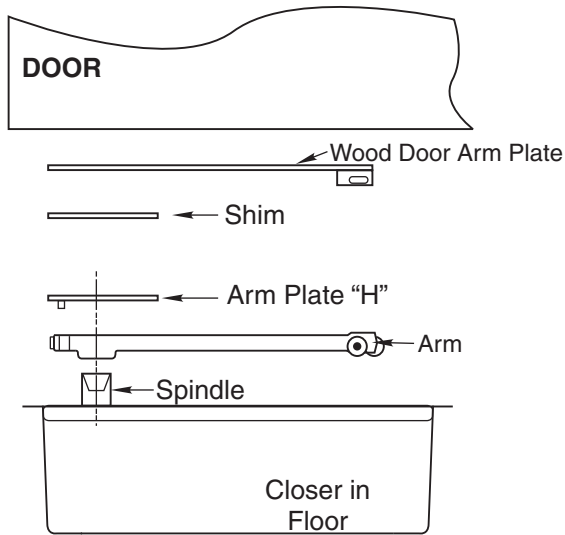

- A. Install top pivot in door per template.
- B. Install top pivot in jamb per template.
- C. Centerline of pivot pin should line up with centerline of spindle. Use plumb line to assure accuracy. If center lines don't line up, loosen hold down screws (4) and reposition closer. Tighten hold down screws closest to spindle first. Then tighten screws at cylinder end. Note: Closer must be lifted approx. 1/8" before repositioning.
- D. Mortise door for arm, arm plate H, and wood door arm plate. Refer to template.
- E. Drill two 9/16" dia. holes for arm alignment screws. Drill 3/8" hole at heel edge of door for adjusting screw.
- F. Attach arm to spindle using spindle screw supplied and tighten securely. Install arm plate H, wood door arm plate, and shim.

### 4. Hang Door

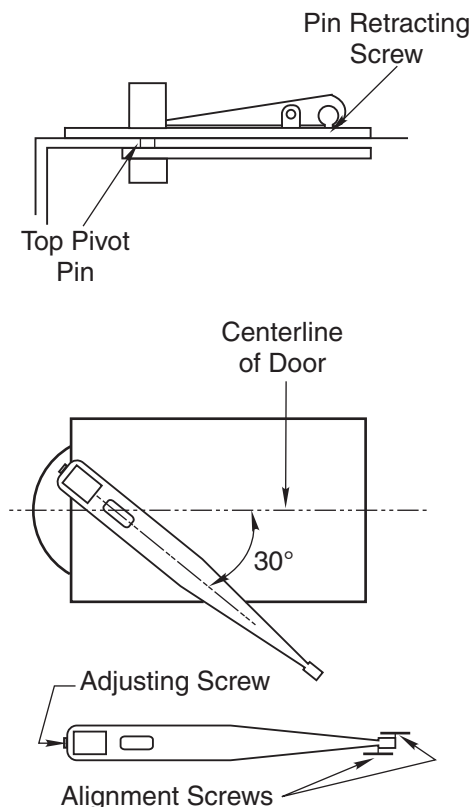

CAUTION: Closer is shipped with "valve" screws down. DO NOT FORCE VALVE DOWN.

- A. Close both valve screws. NEVER FORCE VALVE SCREW DOWN AS THIS WILL DAMAGE TIP SEATING.
- B. With arm on spindle, turn spindle until arm is in 30° open position (see illustration).
- C. Set door on spindle. DO NOT ATTEMPT TO CLOSE DOOR.
- D. Align two portions of top pivot and turn pin retracting screw clockwise to engage top pivot pin.
- E. Open door to 60° or more and turn valve screws counterclockwise. Door will then close.
- F. If necessary, turn adjusting screw at bottom of heel edge of door to equalize side jamb clearances.
- G. Adjust arm alignment screws equally from each side to center door in doorway.

## Closer Adjustment

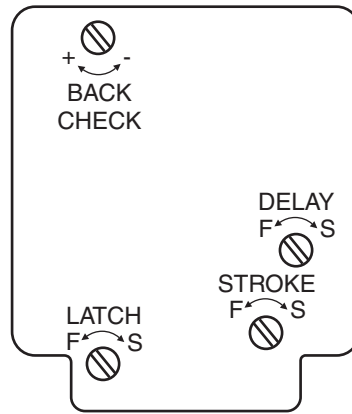

Closing speeds can be adjusted to suit local conditions and requirements. Label on closer face designates the purpose of each adjustment screw. Adjustments are for speed control.

- A. The stroke valve allows adjustment from open to 15°.
- B. The latch valve allows adjustment from 15° to closed position.
- C. **IMPORTANT:** Back check valve option must be adjusted to vary resistance from light to firm at 70° of door opening.
- D. The delay valve option allows closing speed adjustment from open position to 65°.

Repairs, parts replacement or internal adjustments must be done by a Rixson authorized repair agency. Consult [www.rixson.com](http://www.rixson.com) for an authorized repair agency in your area.

ASSA ABLOY is the global leader in door opening solutions, dedicated to satisfying end-user needs for security, safety and convenience.

Rixson® is a registered trademark of Yale Security Inc., an ASSA ABLOY Group company. Copyright© 2005, 2009, Yale Security Inc., an ASSA ABLOY Group company. All rights reserved. Reproduction in whole or in part without the express written permission of Yale Security Inc. is prohibited.