

# F519 Pocket Pivot Installation Instructions

Door should already be hung with top pivot and bottom pivot (or floor closer)

- A. Open Pivot 90° to expose screw holes and attach door leaves of all pivots required to door using appropriate fasteners.
- B. Install door and pivot assembly to jamb by supporting door at the proper height and sliding toward jamb so that pivots enter the jamb pockets and mortises.

- C. With door properly supported and opened approximately 60° or more to expose screw holes. Attach pivot jamb leaf to jamb using appropriate fasteners.

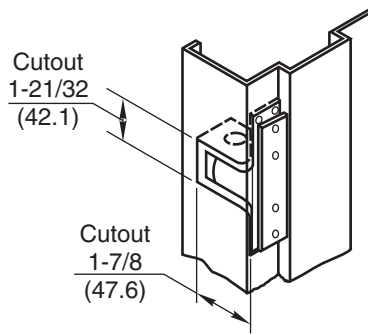

**Right Hand Frame  
(Jamb Style 1)**

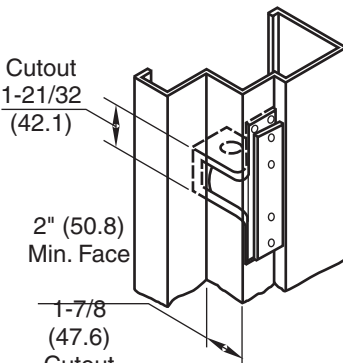

**Right Hand Frame  
(Jamb Style 2)**

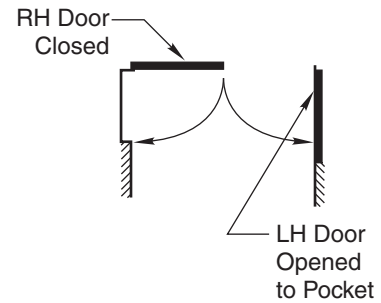

**Key Plan  
Pair of Doors**

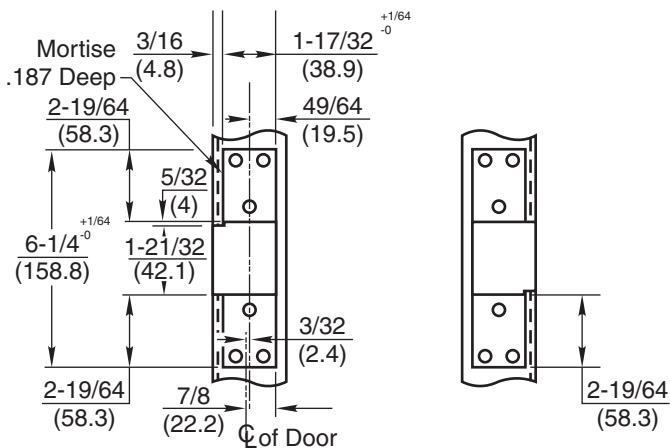

**Mortise Detail, Steel Frame**

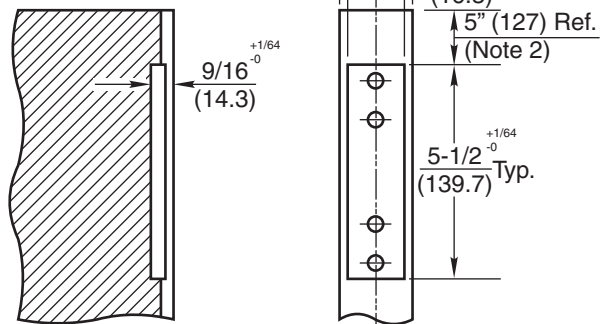

**Wood Application Shown  
Dimensions Same for Steel Door  
Door Mortise Detail**

**Notes:**

1. \* Prepare full length of door to these dims.
2. Use standard spacing to suit size of door.
3. Use 1 pivot for every 30" (762) of door height.
4. Use 1 pivot for every 90 lbs. of door weight.
5. Reinforcement tabs shall leave clear opening of 1-7/8 to allow installation of pivot.

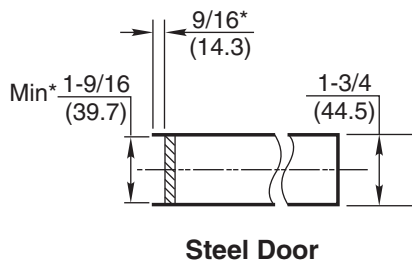

**Steel Door**

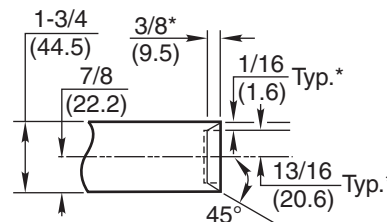

**Wood Door  
(Style 1)**

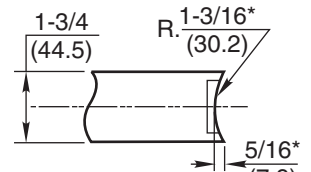

**Wood Door  
(Style 2)**

Door Jamb Clearance 7/64 (2.8) - Hinge Side

**F519 Pocket Pivot**

**RIXSON®**  
**ASSA ABLOY**

www.rixson.com

TEMPLATE NUMBER

**IS-F519**

DATE

**11-09**

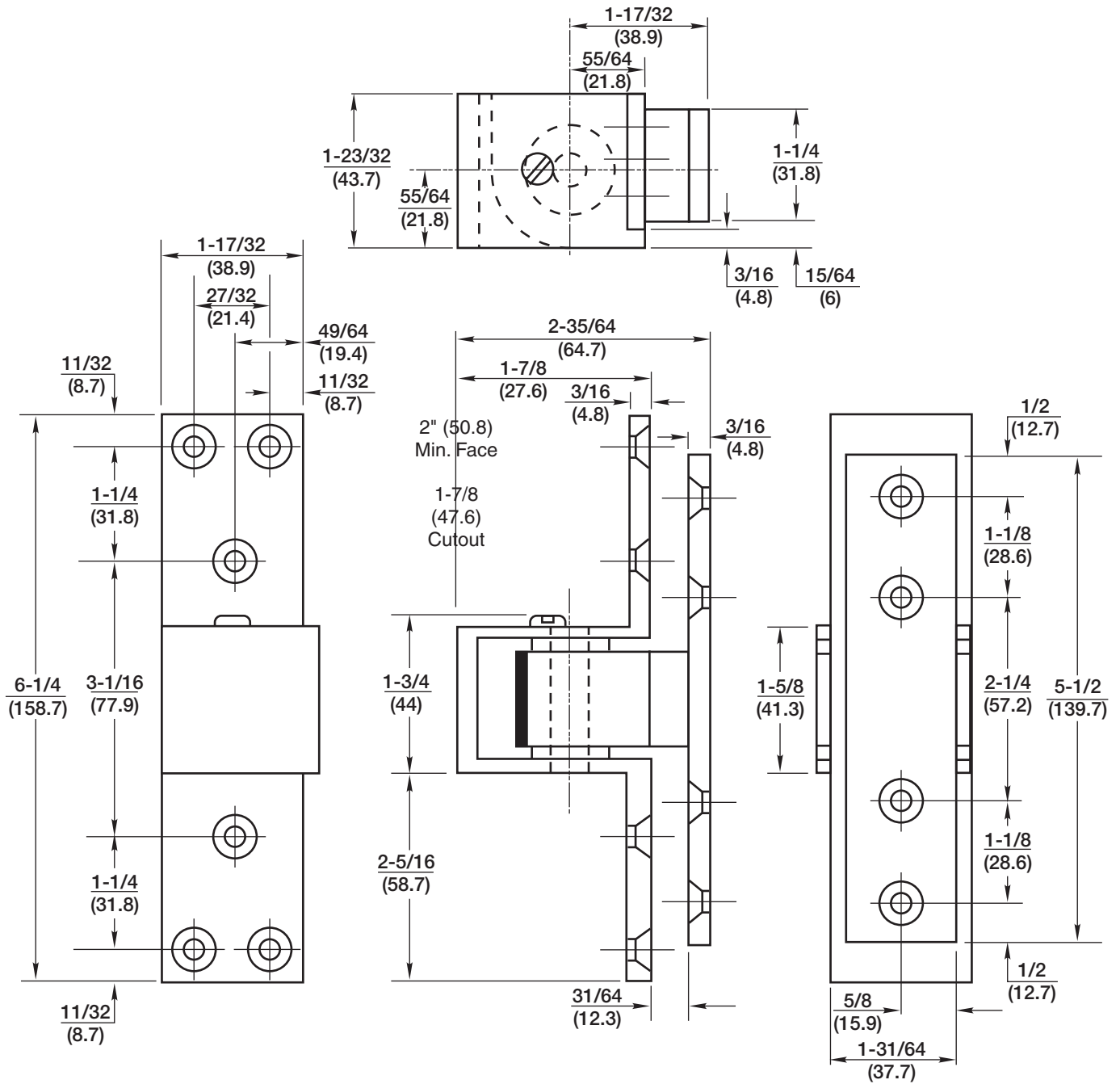

**Notes:**

1. Do not scale drawing.
2. Dimensions are given in inches (mm).
3. Right hand shown.
4. Machine Screw Size #12-24 x 3/4 FHMS  
Wood Screw Size #12 x 1-1/2 FHWS

**F519 Pocket Pivot**

**RIXSON®**  
**ASSA ABLOY**

www.rixson.com

TEMPLATE NUMBER

**IS-F519**

DATE

**11-09**